

# earn2life.com

This is an initial public offering of shares Earn2Life.com. This prospectus relates to an offering of 1,500,000 shares on the SLCAPEX exchange.

## Stock Composition:

| <u>Total Shares</u> |
|---------------------|
| 5,000,000           |

## Initial Public Offering:

| <u>Symbol</u> | <u>Per Share</u> | <u>Shares to IPO</u> | <u>Total</u> |
|---------------|------------------|----------------------|--------------|
| EARN          | L\$2.50          | 1,500,000            | L\$3,750,000 |

# Welcome to Earn2Life.com!

**Dear Fellow Investor,**

Within this prospectus we shall try to reveal the nature of Earn2Life.com to you. This document contains the facts we consider to be the most important for the investor to know.

Please follow the index below to jump directly to the page, or scroll pages one-by-one to reveal the facts about Earn2Life.com.

## Document Contents

|                                 |    |
|---------------------------------|----|
| Welcome to Earn2Life.com! ..... | 2  |
| About Earn2Life.com.....        | 3  |
| Revenue and Expenses .....      | 7  |
| Use of Capital.....             | 8  |
| Dividends Policy .....          | 12 |
| Involving Shareholders .....    | 13 |
| Business Strengths.....         | 14 |
| Risk Factors.....               | 15 |
| Professional Management .....   | 16 |
| Buying Shares .....             | 17 |

# About Earn2Life.com



<http://www.earn2life.com>

Earn2Life.com is the famous Second Life money-making company which allows residents to earn money.

Established in 2007, Earn2Life.com has already proved its stability and profitability for hundreds of thousands of SL residents.

## Money-making Programs

Currently Earn2Life.com offers 3 types of money-making programs for Earn2Life.com members:

1. “Guaranteed Visitors” allows business owners to get the alive visitors. Members earn up to L\$45 per visit.
2. Web surveys and offers (“Web Offers” and “Lindens4Free”) allows to earn up to L\$300 per offer (fixed L\$68 with Lindens4Free).
3. Other programs like “Picks Booster” (very popular in the past), surfing web sites to money, Wiki editor, contests etc.

# About Earn2Life.com (cont)

## Guaranteed Visitors (“Pay4Visit”)

Our primary advertising program, “Guaranteed Visitors” (also known as Pay4Visit) allows business owners to obtain the quality real people traffic for any location.



These visitors stay and actively examine the location. We complete the thousands of visits every day, with hundreds of a new members and dozens of new business owners joining daily.

Program provides the additional options to expose the points of interest of the location; to visitors reply the post-visit survey; to invite all visitors to join SL group etc.

# About Earn2Life.com (cont)

## Web Surveys

AVAILABLE WEB OFFERS

| ID    | Description  | Payment |
|-------|--|---------|
| WB004 | Save MONEY on Your Auto Insurance!<br><a href="#">Open details</a>       | L\$115  |
| WB009 | Take the New South Park Quiz<br><a href="#">Open details</a>             | L\$100  |
| WB001 | Kickass Character<br><a href="#">Open details</a>                        | L\$95   |
| WB011 | The Avatar Quiz<br><a href="#">Open details</a>                          | L\$95   |
| WB012 | Love MTV?<br>-- you've completed this offer --                           | L\$90   |
| WB007 | \$1000 Best Buy Card! Take a 5min survey<br><a href="#">Open details</a> | L\$85   |

Web surveys (“Web Offers”) was the very first program of Earn2Life.com in 2007. We regularly improve this program: currently it allows to earn up to L\$300 per single survey.

The payments are constantly growing, from few hundreds of USD in 2007 up to dozens of thousands in 2010.

## Daughter Web Projects

Besides of “Web Offers”, we launch the subprojects like “Lindens4Free” (<http://www.lindens4free.com>) which are the parts of Earn2Life.com too.

The brand new program is under development now: it’s the comprehensive gangster-style game with levels, ranks and earnings; it’s planned to raise the overall income up to 3-4 times comparing to current values.

Your SL name:

[L\\$68 \(offers set #1\)](#) [L\\$88 worth item \(offers set #2\)](#)

Each survey payment:  
**L\$68**

---

[Start!](#)

# About Earn2Life.com (cont)

## Other Programs



With Earn2Life.com we provide the wide range of possibilities to make money. Besides of the general programs mentioned above, we also:

- Pay our members for E2L Wiki updates. This allows to maintain the wiki in 20 languages - <http://www.earn2life.com/wiki>
- Run contests, like “Team Leaders’ Contest” and “Video Contests”. The prizes start from L\$1,000 per week.
- Encourage Earn2Life.com members to be involved into company’s life and management: support teams, promo teams etc.

This approach greatly enhances the members’ loyalty and keep them interested in our programs.

# Revenue and Expenses

During the last year (since May 2010) we've managed to increase the overall net profit by more than 100%.

This has been done by launching Pay4Links program in June 2010 and Lindens4Free program in November 2010.

## Overall Revenue Chart, 05.2010 - 05.2011

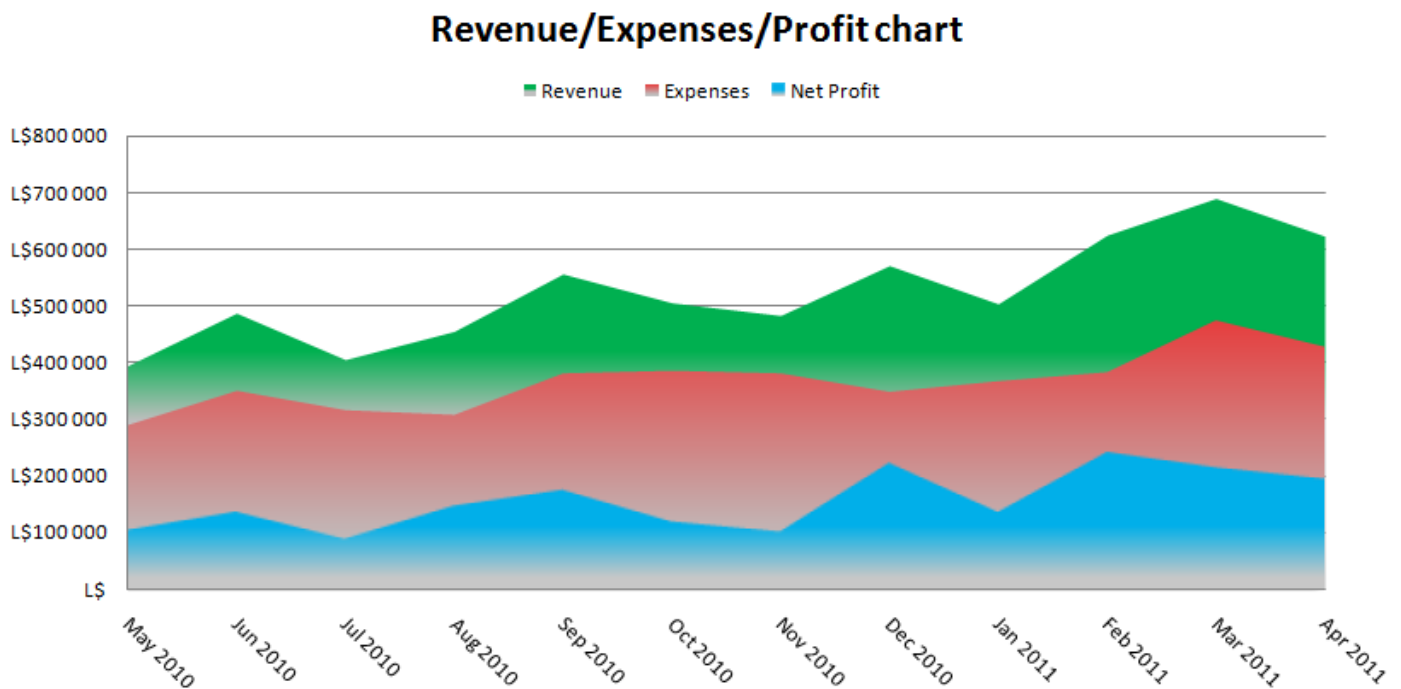

The general dependence you may notice is that current month's revenue increase usually causes the higher next month's expenses.

This is due the delayed nature of Earn2Life.com member payments.

## Major Goals to Achieve

Once the IPO is finished and investments are funded to the company's balance, we shall have three major goals to achieve:

1. Develop the new money-making programs with Earn2Life.com.
2. Attract more advertisers to take part within existing programs.
3. Make our programs more friendly and easy-to-use.

We already have the ready-to-go solution to reach each of these 3 goals. Thus, we don't need to waste time trying different team management approaches: we already have a well-trained team.

## Improving the Environment

We also going to use the investments to develop our Second Life sim, DuoLife. Providing the necessary entertainment services and stores will encourage users of Earn2Life.com to spend more time without leaving the sim, keeping them involved into our projects and programs.

Proceed to the further pages for more info about our plans.

## Developing New Programs

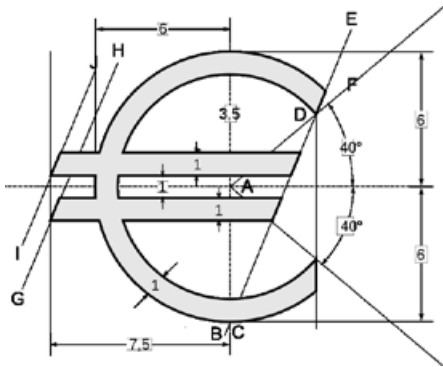

This goal requires the professional programmers to be involved, as we are touching all aspects of web and Second Life programming in our activity.

We will be hiring new programmers (in addition to the currently working on our projects) to cover these requirements and create the high-quality products. These programmers will develop the new programs we've already planned, and also will help maintaining and improving the existing ones.

## Graphics: Web and In-world



Along with developers, we will hire a new visual designer to work solely for Earn2Life.com.

Creating the attractive web site, nice and clear in-world posters and advertising materials will definitely attract new users and advertisers and will help them to start using Earn2Life.com possibilities.

## Attracting New Advertisers

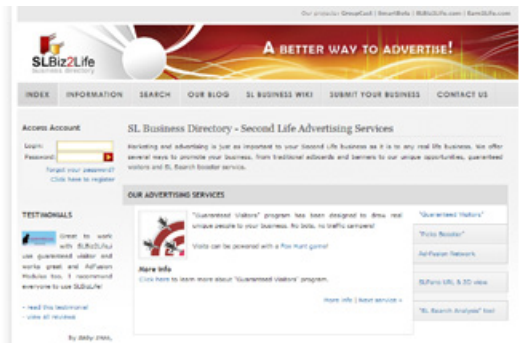

<http://www.slbiz2life.com>

Attracting the new advertisers is a very important aspect of our team activity. We are going to expand our influence and renown by (a) launching the new advertising campaigns (both web and in-world) and (b) improving our sales department.

(a) The advertising department will be organized consisting of designer, the advertising manager and usability analyst. This team will pick out the SL resources to advertise at, monitor the advertising efficiency and choose the best approach for these resources.

(b) We already have the sales department which actively attracts new advertisers to promote their business with Earn2Life.com. Despite of the fact that it's relatively small (4 sales managers in May 2011) we've achieved the average monthly sales of L\$30,000 per manager.

Therefore, we have a well-trained sales team core, and investments will allow hiring new managers to work under control of the experienced staff.

### Improving the Support Team



The third goal is to make Earn2Life.com friendly and easy-to-use both for advertisers and users. This is the aspect we were paying attention to from the very beginning.

Second Life attracts people of different cultures and education, and we already know how to provide the easy and clean solution to suit their needs.

Our support team is currently providing both live and ticket-based support; support managers also maintain the Earn2Life.com wiki project: the multilingual resource to read about Earn2Life.com.

We will improve the support services by extending the time coverage of the live support, and expanding the wiki coverage by adding new documents and languages.

# Dividends Policy

Due to the nature of Earn2Life.com, our primary goal is to provide the constant source of income for all our users, customers and advertisers.

IPO shareholders are not the subject of exclusion. Moreover, the shareholders are the actual co-owners of Earn2Life.com and will benefit from Earn2Life.com success in the first place. Our dividends policy is to pay the appreciable dividends every month, regarding of the net profit gained.

## Dividends and Profit

We plan to pay from 50% to 70% of the profit to dividends. The rest of the profit will be spent on the company's growth (advertising, launching new programs with Earn2Life.com).

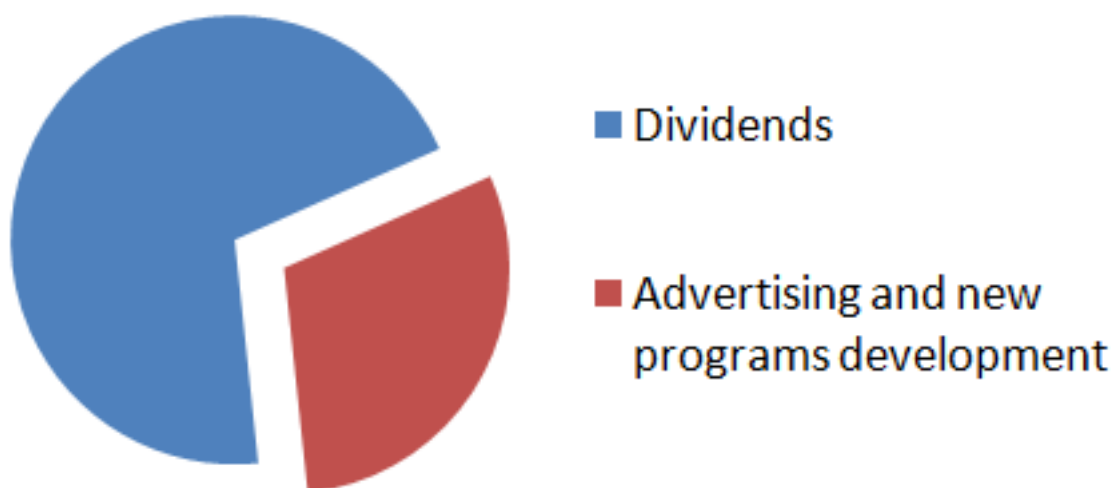

# Shareholders Relations Policy

---

The Earn2Life.com's publicity provides the amazing possibilities for the company, and we are going to utilize these possibilities at 100%.

We shall involve the shareholders into the company's decisions as much as possible, by holding the meetings, publishing the company's plans and using online tools to discuss them.

Discussing the company's future and taking the shareholders' thoughts into account is the efficient way to generate new ideas, especially by involving the concerned persons, and Earn2Life.com Team have a possibility to implement any ideas!

# Business Strengths

Our strengths follow from the nature of our business, the services we offer, and the professional team of managers and developers.

1. Every resident of Second Life enjoys having the source of income. Taking a part in Earn2Life.com programs allows easily archiving that for any resident.
2. On the other side, we provide the controllable, reliable and effective way for Second Life business owners to promote their SL business. Business owners are able to get the constant flow of visitors, alive SL residents with Earn2Life.com.
3. With more than 2 thousands Second Life businesses listed we negate the risks connected with a single business issues and problems. New business joins, existing business owners prosper – that's the key of Earn2Life.com's success.
4. Earn2Life.com has the proven its stability and profitability by being managed by the professional team since 2007. The net profit every month is an outstanding example of Second Life company successfully running and developing through the years.

Any Second Life company is a subject of certain risks. However, these risks mostly relate to the nature of SL itself:

1. Business operations risks in Second Life mostly depend on Linden Labs servers and services operation. These factors are beyond of our control, and activity may be temporary interrupted or stopped because of malfunction of Second Life infrastructure.
2. The major internal risks are the residents trying to cheat Earn2Life.com and its advertisers, both online and offline. Our team constantly fights the cheat attempts developing the new protection measures and approach. Our general point in this fight is to protect advertisers as they have the long-term interests in Second Life.

# Professional Management

---

Running Earn2Life.com through the years, we've gathered the professional team which is able to quickly manage any issue, related both to the technical aspect or human relationships. Most of our team members are also enthusiastic regarding Second Life and developing business in SL.

Successful management is the key success factor, as determining the ways of the company evolution is more important than working with momentary tasks. We have the comprehensive plans how to develop Earn2Life.com company in the future, involving professional developers, scripters, designers, builders and sales representatives.

We are proud of our strong, initiative and goal-seeking top management, and absolutely sure that their leadership will result in the great success and company prosperity!

# Buying Shares

---

The Initial Public Offering (IPO) of stock for Earn2Life.com (EARN) will start on

**Monday, May 16th, at 03:00 AM SLT**

To buy the shares, you have to complete the following steps:

1. Create account with SLCAPEX (visit our in-world terminal)
2. Buy the shares at <http://www.slcapex.com>

## Buying Shares Instructions

Visit the web page we've composed to provide the detailed step-by-step instructions: [http://www.earn2life.com/wiki/Buy\\_Earn2Life\\_Shares](http://www.earn2life.com/wiki/Buy_Earn2Life_Shares)

## Special Arrangements and Bonuses

If you would like to buy a large share amount (L\$250,000+), please contact Glaznah Gassner in-world.

## Bonuses for Advertisers

We will provide the advertisement bonuses for all our customers who buy Earn2Life.com shares during the IPO.

If you are:

- an existing Earn2Life.com advertiser (registered with SLBiz2Life)
- or wish to start advertising with Earn2Life.com

visit this page for the Customer's Reward Program:

[http://www.slbiz2life.com/business-wiki/Earn2Life\\_IPO\\_Bonuses](http://www.slbiz2life.com/business-wiki/Earn2Life_IPO_Bonuses).